

ALTERNATORS

LSA 42.2 - 4 Pole - Three phase

Electrical and mechanical data

TYPICAL DATA

Insulation class	H	Excitation system	Shunt	A R E P
Winding pitch - Code	2/3 - (N° 6)	A.V.R. model	R 250	R 438
Wires	12	Voltage regulation (steady state)	± 0,5 %	± 0,5 %
Drip proof	IP 23	Sustained short-circuit current	-	300% (3 IN) : 10s
Altitude	≤ 1000 m	Total harmonic (*) TGH / THC	< 4 %	< 4 %
Overspeed	2250 min⁻¹	Wave form : NEMA = TIF - (*)	< 50	< 50
Air flow	0,15 m³/s	Wave form : I.E.C. = THF - (*)	< 2 %	< 2 %

(*) Total harmonic content line to line, at no load or full rated linear and balanced load

RATINGS : kVA / kW - Power factor = 0,8

Duty/Ambiant T°	Continuous / 40°C								Stand-by / 40°C				Stand-by / 27°C			
	H / 125° K				F / 105° K				H / 150° K				H / 163° K			
Class/T° rise	3 ph.		1 ph.		3 ph.		1 ph.		3 ph.		1 ph.		3 ph.		1 ph.	
Y	380V	400V	415V	Δ Δ	380V	400V	415V	Δ Δ	380V	400V	415V	Δ Δ	380V	400V	415V	Δ Δ
Δ	220V	230V	240V	230V	220V	230V	240V	230V	220V	230V	240V	230V	220V	230V	240V	230V
42.2 S4	kVA	17,5	11		17	10			20	12			21	12,5		
	kW	14	8,8		13,6	8			16	9,6			16,8	10		
42.2 S5	kVA	20	12,5		19,5	11,6			24	13,5			25	14,1		
	kW	16	10		15,6	9,3			19	10,8			19,8	11,3		
42.2 M6	kVA	23	14		21	13			27	15			28	15,5		
	kW	18,4	11,2		16,8	10,4			21,4	12			22,4	12,4		
42.2 M7	kVA	27	16		25	15			30	17,4			31	18,2		
	kW	21,6	12,8		20	11,9			23,8	13,9			24,8	14,6		
42.2 L9	kVA	31,5	18,5		28,5	17,1			33,4	20			35	20,6		
	kW	25,2	14,8		23	13,7			26,7	15,9			27,8	16,5		

EFFICIENCIES (%) : Class H . 40° C

	Three phase : 400 V										Single phase : 230 V									
	P.F. = 0,8					P.F. = 1					P.F. = 0,8					P.F. = 1				
	1/4	2/4	3/4	4/4	St.by	1/4	2/4	3/4	4/4	St.by	1/4	2/4	3/4	4/4	St.by	1/4	2/4	3/4	4/4	St.by
42.2 S4	82,9	87,4	88	87,6	87,2	84,9	90,2	91,5	91,6	91,5	75,7	81,6	82,2	81,3	80,6	78	85,2	86,9	87,1	86,9
42.2 S5	84,2	87,8	87,9	87	86,6	86,2	90,8	91,6	91,5	91,2	77,2	82	81,9	80,4	79,6	79,8	86	87,1	86,8	86,5
42.2 M6	85	89,2	89,8	89,4	89,1	86,6	91,5	92,6	92,8	92,7	78	83,9	84,7	84,1	83,7	79,9	86,8	88,5	88,7	88,6
42.2 M7	86,4	89,6	89,7	88,9	88,5	88,1	92,1	92,8	92,6	92,4	79,6	84,3	84,5	83,5	82,9	81,6	87,5	88,7	88,5	88,3
42.2 L9	87,9	90,3	90	89	88,6	89,6	92,8	93,1	92,7	92,5	81,7	85,4	85,1	83,7	83,1	83,7	88,6	89,2	88,7	88,4

REACTANCES (%) - TIME CONSTANTS (ms) : CLASS : H / 400 V

		42.2 S4	42.2 S5	42.2 M6	42.2 M7	42.2 L9
Kcc	Short-circuit ratio	0,76	0,66	0,71	0,6	0,51
Xd	Direct axis synchronous reactance unsaturated	160	190	170	200	220
Xq	Quadrature axis synchronous reactance unsaturated	80	90	80	100	110
T'do	Open circuit time constant	410	410	450	450	470
X'd	Direct axis transient reactance saturated	10,1	11,5	9,3	10,9	11,8
T'd	Short circuit transient time constant	30	30	30	30	30
X"d	Direct axis subtransient reactance saturated	5,0	5,8	4,6	5,5	5,9
T"d	Subtransient time constant	3	3	3	3	3
X"q	Quadrature axis subtransient reactance saturated	7,1	8,1	6,5	7,7	8,4
Xo	Zero sequence reactance unsaturated	0,8	0,1	0,6	0,2	0,3
X2	Negative sequence reactance saturated	6,0	6,9	5,6	6,6	7,1
Ta	Armature time constant	4	4	4	4	4

OTHER DATA - CLASS : H / 400 V -

		42.2 S4	42.2 S5	42.2 M6	42.2 M7	42.2 L9
io	No load excitation current (A) (SHUNT/AREP)	0,6/0,9	0,6/0,9	0,5/0,8	0,5/0,8	0,5/0,7
ic	Full load excitation current (A) (SHUNT/AREP)	1,4/2,1	1,6/2,3	1,3/2	1,5/2,3	1,5/2,3
uc	Full load excitation voltage (V) (SHUNT/AREP)	36/13	40/14	34/12	39/14	39/14
ms	Recovery time(ΔU =20 % trans.)	500	500	500	500	500
kVA (Shunt)	Motor start. (ΔU = 20% sust.) or (ΔU = 50% Transient)	44	50	54	64	69
kVA (AREP)	Motor start. (ΔU = 20% sust.) or (ΔU = 50% Transient)	51	59	64	75	80
%	Transient dip (rated step load) - PF : 0,8 LAG	13,6	14,7	13,1	14,5	15,6
W	No load losses	590	590	690	690	680
W	Heat rejection	2000	2400	2200	2700	3100

According to : I.E.C. 34.1/34.2 - U.T.E. : NF C 51.111 - V.D.E. 0530 - B.S. 4999 & 5000 - NEMA : MG 1.22 - ISO 8528 . 3 - CSA (upon request)
 Products and materials shown in this catalogue may, at any time, be modified in order to follow the latest technological developments, improve the design or change conditions of utilization.
 Their description cannot, in any case, engage Leroy-Somer liability. The values indicated are typical values .

TRANSIENT VOLTAGE VARIATION - 400V

Load application

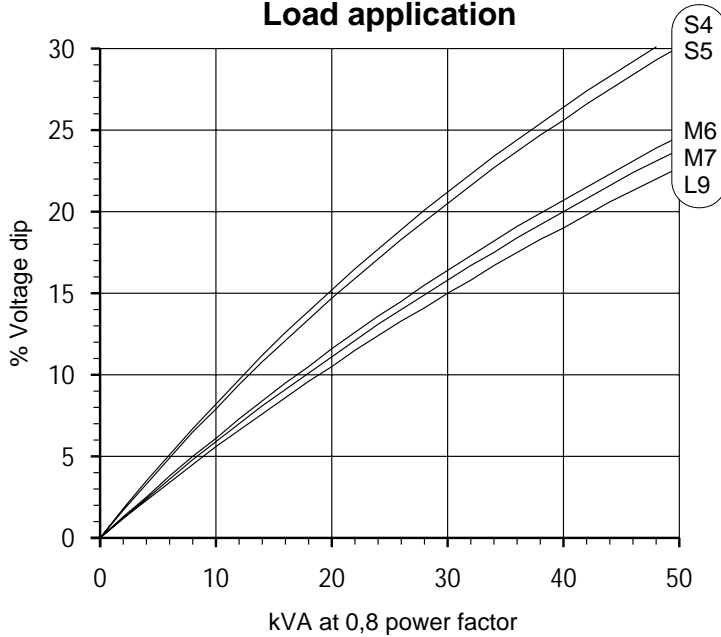

Load rejection

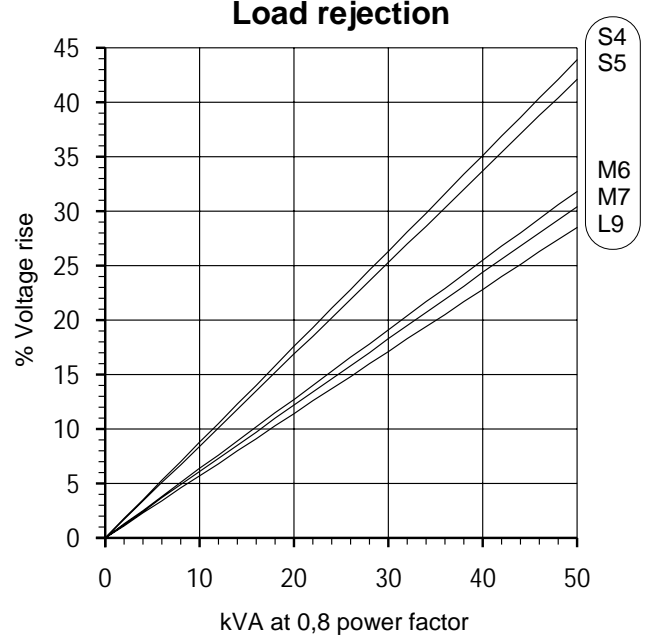

Motor starting

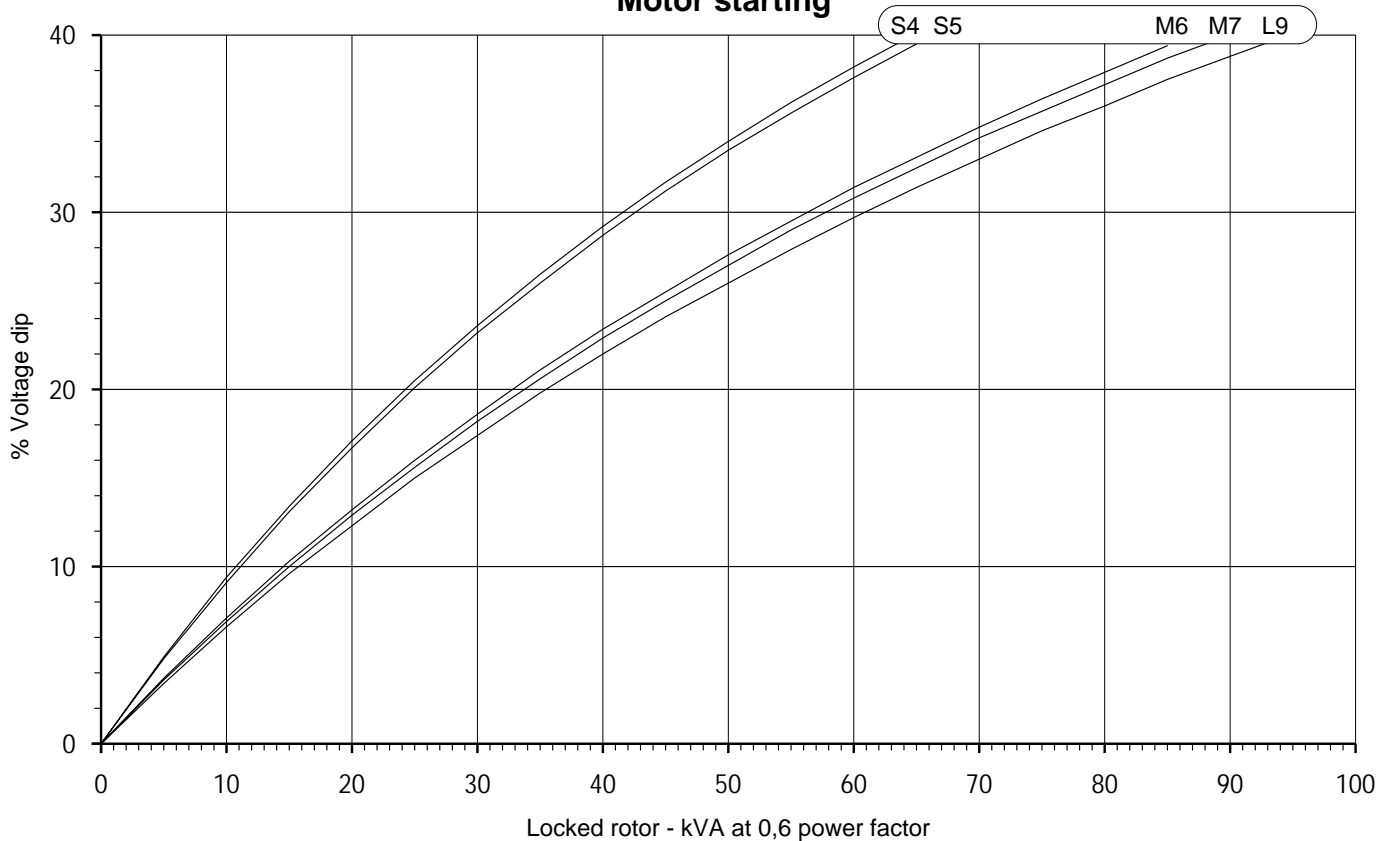

- 1) For a starting P.F. differing from 0,6 the starting kVA have to be multiplied by $(\text{Sine } \varnothing / 0,6)$
- 2) If voltage is not 400V(Y) , 230V(Δ) at 50 Hz then kVA must be multiplied by $(400/U)^2$ or $(230/U)^2$.

Products and materials shown in this catalogue may, at any time, be modified in order to follow the latest technological developments, improve the design or change conditions of utilization. Their description cannot, in any case, engage Leroy-Somer liability. The values indicated are typical values .

TYPICAL DATA

Insulation class	H	Excitation system	Shunt	A R E P
Winding pitch - Code	2/3 - (N° 6)	A.V.R. model	R 250	R 438
Wires	12	Voltage regulation (steady state)	± 0,5 %	± 0,5 %
Drip proof	IP 23	Sustained short-circuit current	-	300% (3 IN) : 10s
Altitude	≤ 1000 m	Total harmonic (*) TGH / THC	< 4 %	< 4 %
Overspeed	2250 min⁻¹	Wave form : NEMA = TIF - (*)	< 50	< 50
Air flow	0,18 m³/s	Wave form : I.E.C. = THF - (*)	< 2 %	< 2 %

(*) Total harmonic content line to line, at no load or full rated linear and balanced load

RATINGS : kVA / kW - Power factor = 0,8

Duty/Ambiant T°	Continuous / 40°C										Stand-by / 40°C					Stand-by / 27°C					
	H / 125° K					F / 105° K					H / 150° K					H / 163° K					
	Phase	3 ph.			1 ph.	3 ph.			1 ph.	3 ph.			1 ph.	3 ph.			1 ph.				
Y	380V	416V	440V	480V	Δ Δ	380V	416V	440V	480V	Δ Δ	380V	416V	440V	480V	Δ Δ	380V	416V	440V	480V	Δ Δ	
Δ		240V			240V		240V			240V		240V			240V		240V			240V	
YY		208V	220V	240V		208V	220V	240V		208V	220V	240V		208V	220V	240V		208V	220V	240V	
42.2 S4	kVA	21	22	22	22	13,1	19	21,1	21,2	21,2	12,5	22	25	25,4	25,4	15	23	26	26,4	26,4	16,3
	kW	17	18	18	18	10,5	15	17	17	17	10	18	20	20,3	20,3	12	18,5	20,5	21	21	13
42.2 S5	kVA	24	26	26	26	15,6	21,5	24,6	25	25,4	15	25	29,7	30,1	30,1	16,9	26	30,7	31,5	31,5	17,5
	kW	19	21	21	21	12,5	17	20	20	20,3	12	20	24	24,1	24,1	13,5	21	24,6	25	25	14
42.2 M6	kVA	28	31	31	31	18,7	25	27,3	27,5	28,2	16,9	29	34	34	34,5	20	31	34,5	35	35,5	21,3
	kW	22	25	25	25	15	20	22	22	22,6	13,5	23	27,2	27,2	27,6	16	25	27,6	28	28,4	17
42.2 M7	kVA	31	34	34	34	20	28	30,9	31,2	31,9	18,8	33	35,8	36,8	37,4	21,3	34	37,5	38,4	39,1	21,9
	kW	25	27	27	27	16	22	24,7	25	25,5	15	26	28,6	29,4	30	17	27	30	30,7	31,3	17,5
42.2 L9	kVA	33	36	38	38	21,3	30	33,7	35	35,6	20	35	39,1	40,4	41,7	22,5	36	40,5	41,7	43,6	23,8
	kW	26	29	30,5	30,5	17	24	27	28	28,5	16	28	31,3	32,3	33,4	18	29	32,4	33,4	35	19

EFFICIENCIES (%) : Class H . 40° C

	Three phase : 480 V										Single phase : 240 V									
	P.F. = 0,8					P.F. = 1					P.F. = 0,8					P.F. = 1				
	1/4	2/4	3/4	4/4	St.by	1/4	2/4	3/4	4/4	St.by	1/4	2/4	3/4	4/4	St.by	1/4	2/4	3/4	4/4	St.by
42.2 S4	82,5	87,7	88,6	88,4	88,2	84,1	90	91,5	91,9	91,9	78,2	83,4	83,6	82,5	81,9	80,2	86,5	87,7	87,5	87,2
42.2 S5	84,3	88,2	88,6	87,9	87,5	86	90,8	91,8	91,8	91,7	80,2	83,7	83	81,2	80,4	82,3	87,2	87,6	86,9	86,4
42.2 M6	85,2	89,5	90,2	90	89,7	86,7	91,6	92,8	93	92,9	81,3	85,4	85,3	84,1	83,5	83,1	88,3	89,1	88,7	88,4
42.2 M7	86	89,8	90,2	89,7	89,4	87,5	91,9	92,9	92,9	92,8	82	85,6	85,1	83,6	83	83,8	88,5	89,1	88,5	88,1
42.2 L9	87,2	90,5	90,7	90	89,7	88,6	92,5	93,3	93,2	93	82,7	86	85,5	84	83,3	84,4	88,9	89,3	88,7	88,3

REACTANCES (%) - TIME CONSTANTS (ms) : CLASS : H / 480 V

		42.2 S4	42.2 S5	42.2 M6	42.2 M7	42.2 L9
Kcc	Short-circuit ratio	0,72	0,6	0,62	0,57	0,51
Xd	Direct axis synchronous reactance unsaturated	170	210	190	210	220
Xq	Quadrature axis synchronous reactance unsaturated	90	100	100	100	110
T'do	Open circuit time constant	410	410	450	450	470
X'd	Direct axis transient reactance saturated	10,6	12,6	10,5	11,5	12,0
T'd	Short circuit transient time constant	30	30	30	30	30
X"d	Direct axis subtransient reactance saturated	5,3	6,3	5,3	5,7	6
T"d	Subtransient time constant	3	3	3	3	3
X"q	Quadrature axis subtransient reactance saturated	7,4	8,8	7,4	8,1	8,4
Xo	Zero sequence reactance unsaturated	1	0,2	0,5	0,5	0,6
X2	Negative sequence reactance saturated	6,4	7,6	6,3	6,9	7,2
Ta	Armature time constant	4	4	4	4	4

OTHER DATA - CLASS : H / 480 V -

		42.2 S4	42.2 S5	42.2 M6	42.2 M7	42.2 L9
io	No load excitation current (A) (SHUNT/AREP)	0,6/0,9	0,6/0,9	0,5/0,8	0,5/0,8	0,5/0,7
ic	Full load excitation current (A) (SHUNT/AREP)	1,4/2,1	1,6/2,4	1,3/2,1	1,5/2,3	1,5/2,2
uc	Full load excitation voltage (V) (SHUNT/AREP)	36/13	40/15	34/13	39/14	39/14
ms	Recovery time(ΔU =20 % trans.)	500	500	500	500	500
kVA (Shunt)	Motor start. (ΔU = 20% sust.) or (ΔU = 50% Transient)	58	63	73	83	91
kVA (AREP)	Motor start. (ΔU = 20% sust.) or (ΔU = 50% Transient)	70	76	87	98	106
%	Transient dip (rated step load) - PF : 0,8 LAG	14	15,6	14,2	15	15,7
W	No load losses	810	810	940	940	930
W	Heat rejection	2300	2900	2800	3100	3400

According to : I.E.C. 34.1/34.2 - U.T.E. : NF C 51.111 - V.D.E. 0530 - B.S. 4999 & 5000 - NEMA : MG 1.22 - ISO 8528 . 3 - CSA .

Products and materials shown in this catalogue may, at any time, be modified in order to follow the latest technological developments, improve the design or change conditions of utilization. Their description cannot, in any case, engage Leroy-Somer liability. The values indicated are typical values .

TRANSIENT VOLTAGE VARIATION - 480 V

Load application

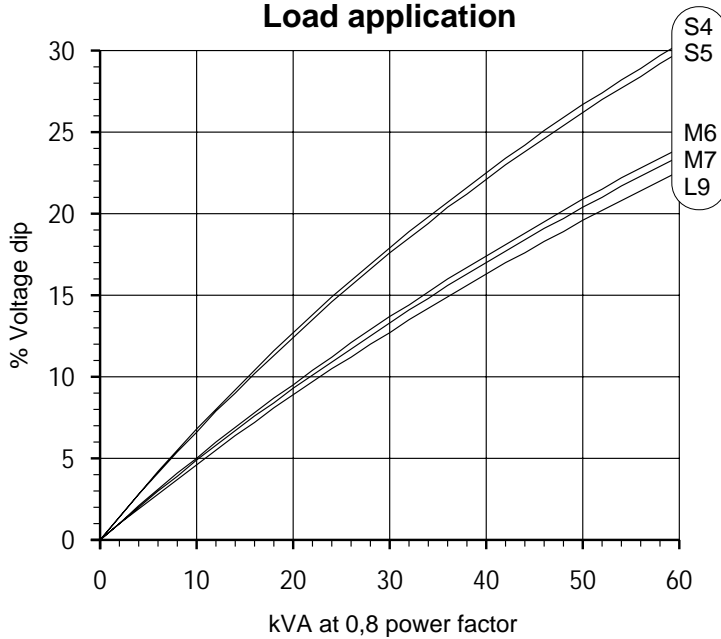

Load rejection

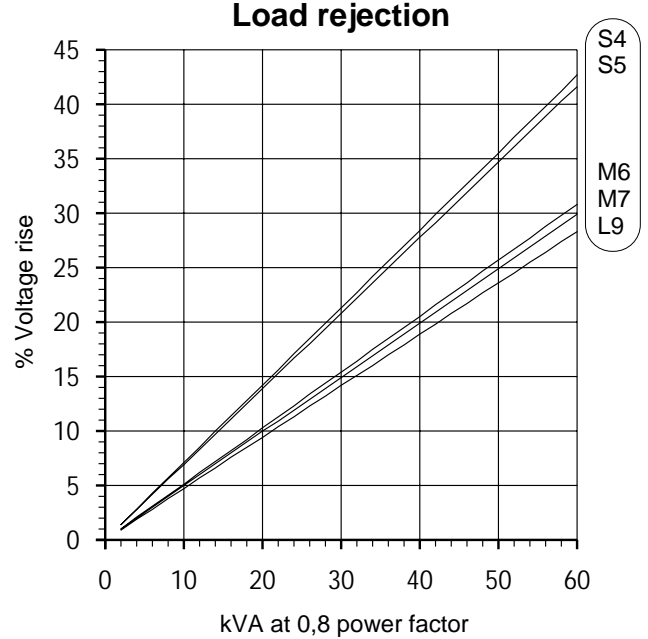

Motor starting

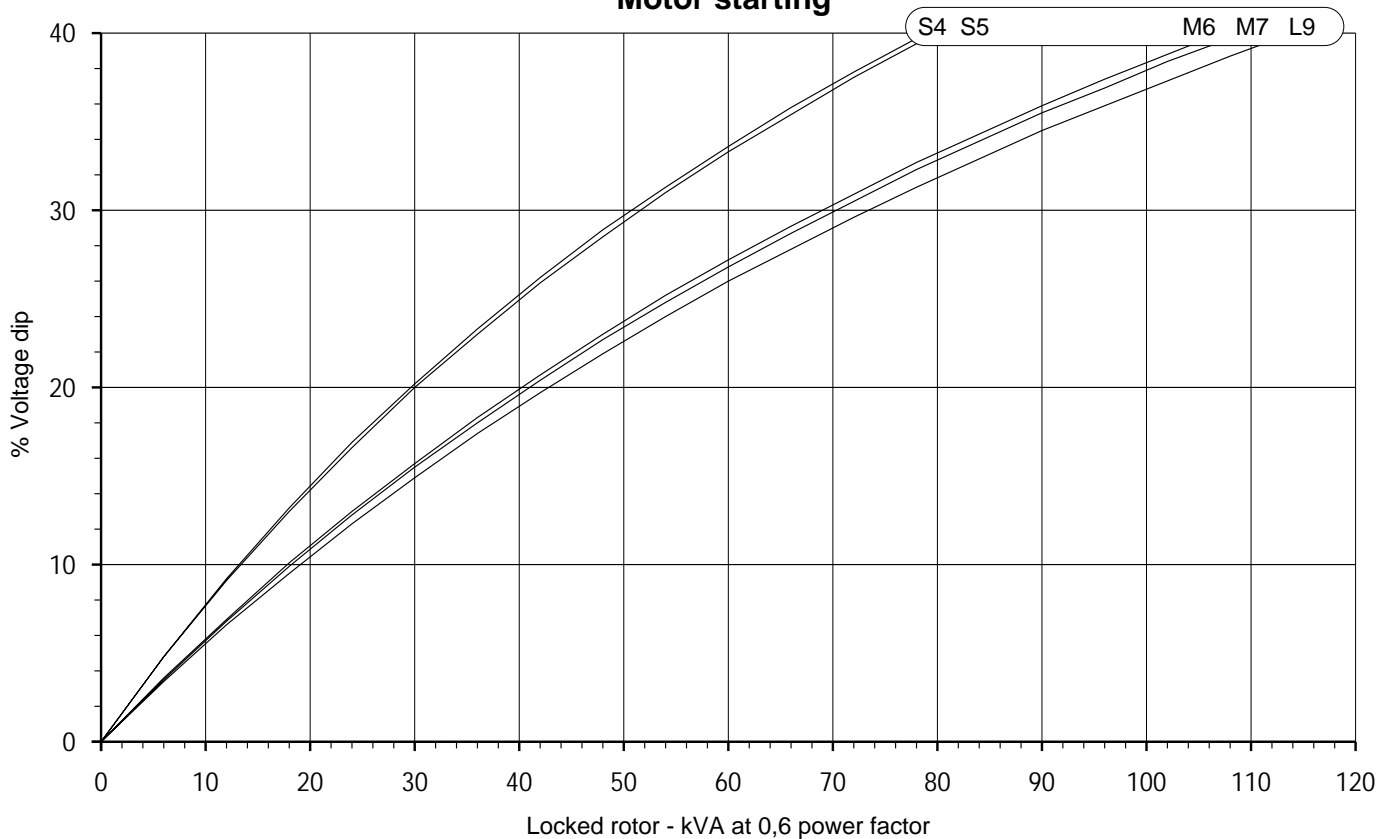

1) For a starting P.F. differing from 0,6 the starting kVA have to be multiplied by $(\text{Sine } \varnothing / 0,6)$
 If voltage is not 480V(Y), 277V(Δ), 240V(Υ) at 60 Hz then kVA must be multiplied by $(480/U)^2$ or $(277/U)^2$ or $(240/U)^2$.

Products and materials shown in this catalogue may, at any time, be modified in order to follow the latest technological developments, improve the design or change conditions of utilization. Their description cannot, in any case, engage Leroy-Somer liability. The values indicated are typical values.

DIMENSIONS

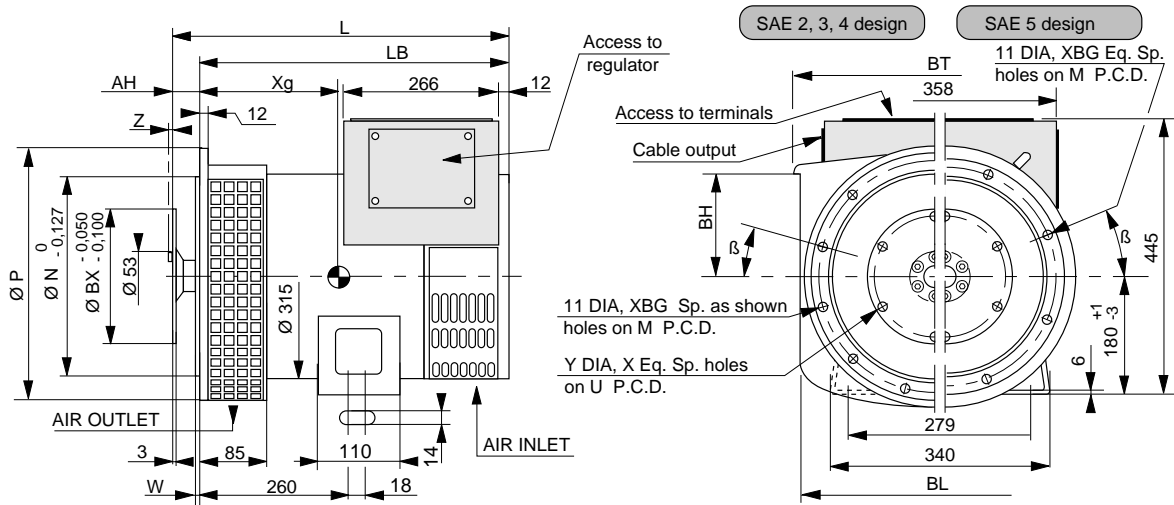

FRAME DIMENSIONS (mm) Mass (kg)

TYPE	L maxi	LB	Xg	M
LSA 42.2 S4	510	448	220	125
LSA 42.2 S5	510	448	220	125
LSA 42.2 M6	565	503	240	142
LSA 42.2 M7	565	503	240	142
LSA 42.2 L9	595	533	260	155

FLANGE DIMENSIONS (mm)

	N	M	XBG	W	β°
S.A.E. 5	314,325	333,375	8	5	22°30'
S.A.E. 4	361,95	381	10	5	15°
S.A.E. 3	409,575	428,625	10	6	15°
S.A.E. 2	447,675	466,725	10	6	15°

FLANGE

	P	BL	BH	BT	COUPLING POSSIBILITY				
					6 1/2	7 1/2	8	10	11 1/2
S.A.E. 5	355	-	-	-	●	●			
S.A.E. 4	408	410	129	432	●	●	●	●	
S.A.E. 3	450	452	155	474			●	●	●
S.A.E. 2	490	492	164	514				●	●

FLEX PLATE DIMENSIONS (mm)

S.A.E.	BX	U	X	Y	AH	Z
11 1/2	352,42	333,38	8	11	39,6	0
10	314,32	295,28	8	11	53,8	0
8	263,52	244,48	6	11	62	0
7 1/2	241,3	222,25	8	9	30,2	5
6 1/2	215,9	200,02	6	9	30,2	5

TORSIONAL ANALYSIS DATA

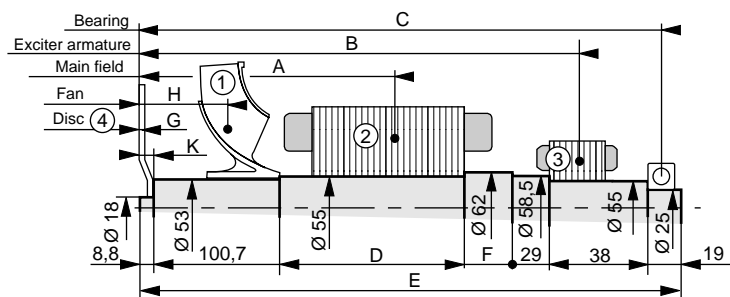
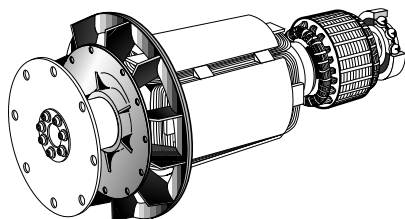

CENTER OF GRAVITY (mm)

TYPE	Disc	A	B	C	D	E	F	G	H	K
S4/S5	11 1/2	247,1	436,6	468,1	204,5	472	72	3,3	102	15,4
	10	261,3	450,8	482,3	204,5	472	72	8,6	116	29,6
	8	269,5	459	490,5	204,5	472	72	12	124,3	37,8
	7 1/2	237,7	427,2	458,7	204,5	472	72	1,5	92,5	6
	6 1/2	237,7	427,2	458,7	204,5	472	72	1,5	92,5	6
M6/M7	11 1/2	274,6	491,6	523,7	259,5	527	72	3,3	102	15,4
	10	288,8	505,8	537,3	259,5	527	72	8,6	116	29,6
	8	297	514	545,5	259,5	527	72	12	124,3	37,8
	7 1/2	265,2	482,2	513,7	259,5	527	72	1,5	92,5	6
	6 1/2	265,2	482,2	513,7	259,5	527	72	1,5	92,5	6
L9	11 1/2	289,6	521,6	553,1	289,5	557	72	3,3	102	15,4
	10	303,8	535,8	567,3	289,5	557	72	8,6	116	29,6
	8	312	544	575,5	289,5	557	72	12	124,3	37,8
	7 1/2	280,2	512,2	543,7	289,5	557	72	1,5	92,5	6
	6 1/2	280,2	512,2	543,7	289,5	557	72	1,5	92,5	6

MASS : kg / MOMENTS OF INERTIA J : kgm², (4J = MD²)

		(1)		(2)		(3)		(4)		TOTAL	
		M	J	M	J	M	J	M	J	M	J
S4/S5	11 1/2	0,25	0,0026	30,5	0,091	4,7	0,018	2,3	0,027	37,75	0,1386
	10	0,25	0,0026	30,5	0,091	4,7	0,018	1,8	0,018	37,25	0,1296
	8	0,25	0,0026	30,5	0,091	4,7	0,018	1,3	0,009	36,75	0,1206
	7 1/2	0,25	0,0026	30,5	0,091	4,7	0,018	1	0,0055	36,45	0,1171
	6 1/2	0,25	0,0026	30,5	0,091	4,7	0,018	0,85	0,0036	36,3	0,1152
M6/M7	11 1/2	0,25	0,0026	41	0,12	4,7	0,018	2,3	0,027	48,25	0,1676
	10	0,25	0,0026	41	0,12	4,7	0,018	1,8	0,018	47,75	0,1586
	8	0,25	0,0026	41	0,12	4,7	0,018	1,3	0,009	47,25	0,1496
	7 1/2	0,25	0,0026	41	0,12	4,7	0,018	1	0,0055	46,95	0,1461
	6 1/2	0,25	0,0026	41	0,12	4,7	0,018	0,85	0,0036	46,8	0,1442
L9	11 1/2	0,25	0,0026	48	0,135	4,7	0,018	2,3	0,027	55,25	0,1826
	10	0,25	0,0026	48	0,135	4,7	0,018	1,8	0,018	54,75	0,1736
	8	0,25	0,0026	48	0,135	4,7	0,018	1,3	0,009	54,25	0,1646
	7 1/2	0,25	0,0026	48	0,135	4,7	0,018	1	0,0055	53,95	0,1611
	6 1/2	0,25	0,0026	48	0,135	4,7	0,018	0,85	0,0036	53,8	0,1592

DIMENSIONS

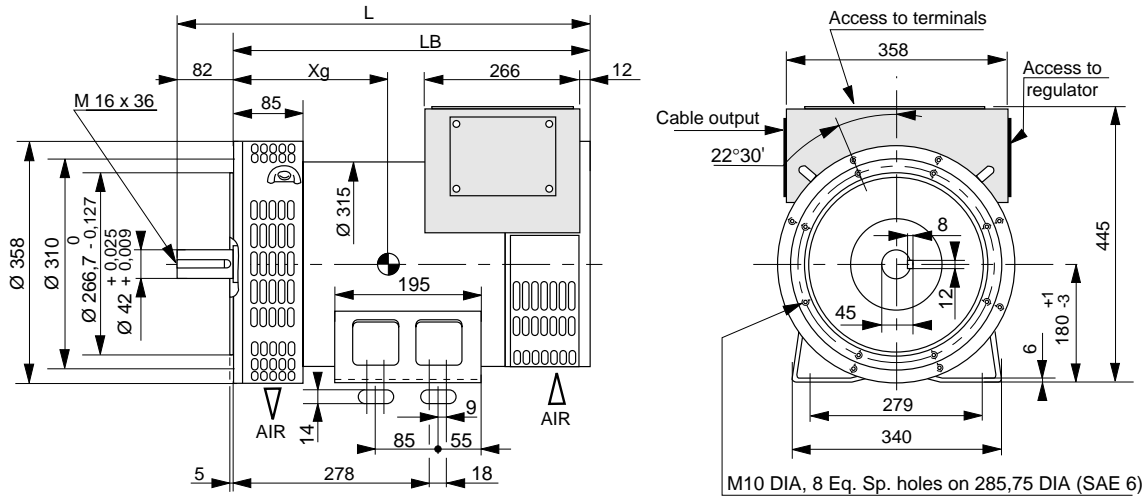

FRAME DIMENSIONS (mm)

TYPE	L maxi	LB	Xg	Mass (kg)
LSA 42.2 S4	548	466	240	120
LSA 42.2 S5	548	466	240	120
LSA 42.2 M6	603	521	260	135
LSA 42.2 M7	603	521	260	135
LSA 42.2 L9	633	551	280	150

TORSIONAL ANALYSIS DATA

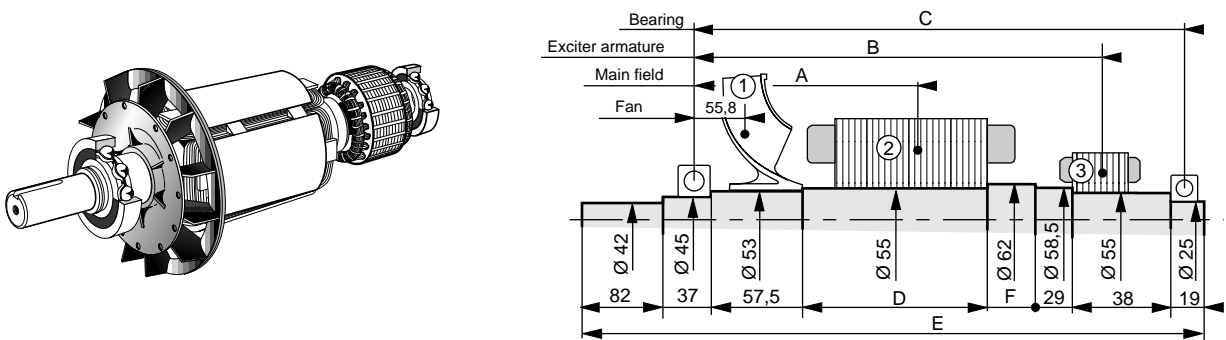

CENTER OF GRAVITY (mm)

TYPE	A	B	C	D	E	F
S4	201	390,5	422	204,5	539	72
S5	201	390,5	422	204,5	539	72
M6	228,5	445,5	477	259,5	594	72
M7	228,5	445,5	477	259,5	594	72
L9	243,5	475,5	507	289,5	624	72

MASS : kg / MOMENTS OF INERTIA J : kgm², (4J = MD²)

(1)		(2)		(3)		TOTAL	
M	J	M	J	M	J	M	J
0,25	0,0026	30,5	0,091	4,7	0,018	35,45	0,1116
0,25	0,0026	30,5	0,091	4,7	0,018	35,45	0,1116
0,25	0,0026	41	0,12	4,7	0,018	45,95	0,1406
0,25	0,0026	41	0,12	4,7	0,018	45,95	0,1406
0,25	0,0026	48	0,135	4,7	0,018	52,95	0,1556

Products and materials shown in this catalogue may, at any time, be modified in order to follow the latest technological developments, improve the design or change conditions of utilization. Their description cannot, in any case, engage Leroy-Somer liability. The values indicated are typical values.

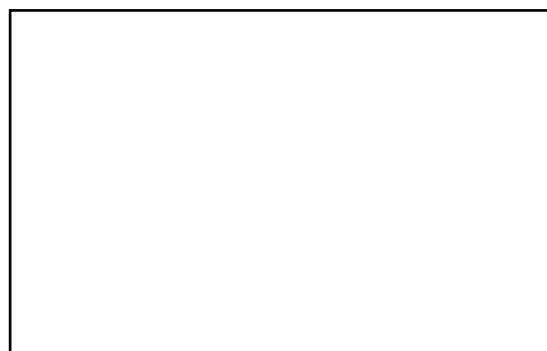

MOTEURS LEROY-SOMER 16015 ANGOULÊME CEDEX - FRANCE

RCS ANGOULÊME N° B 671 820 223
S.A. au capital de 131 910 700 F